

Diatonic Semitones/Half Steps

Diatonic means Different

Circle and name the key that is a diatonic semitone/half step above.

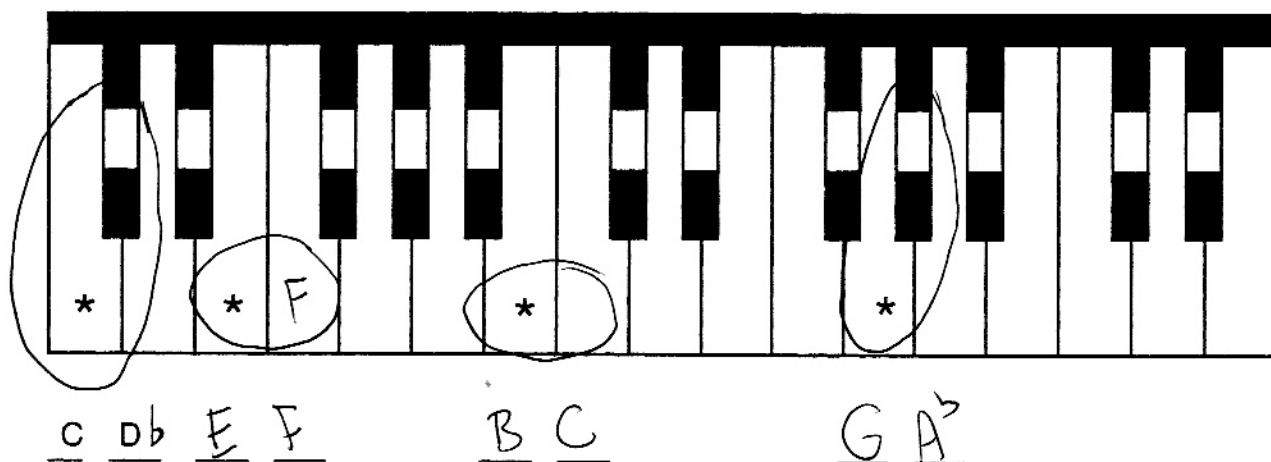

Circle and name the key that is a diatonic semitone/half step below.

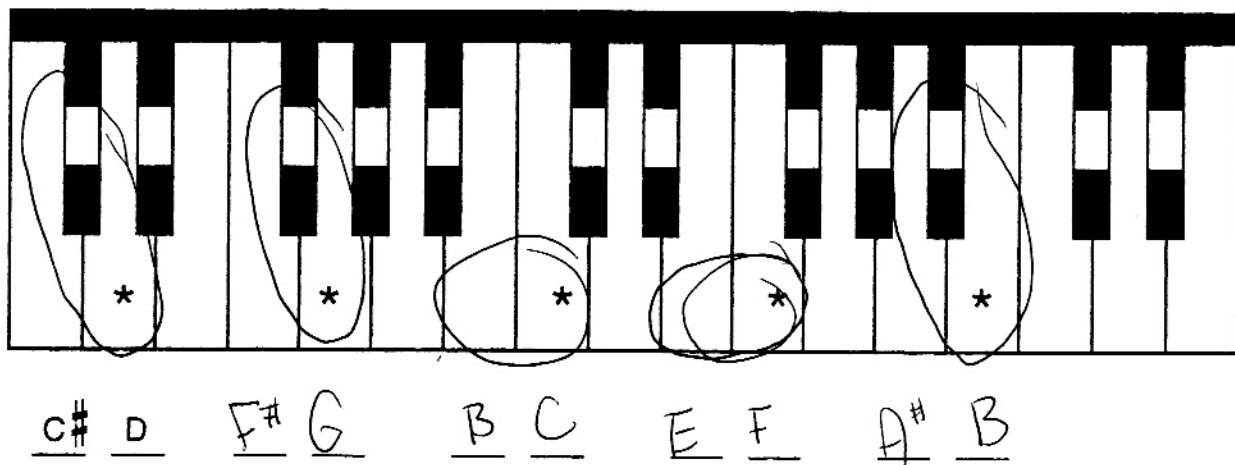

Diatonic

Diatonic semitones/half steps have Different letter names. Remember D and D?

Draw a diatonic semitone/half step above the following notes.



Draw a diatonic semitone/half step below these notes.

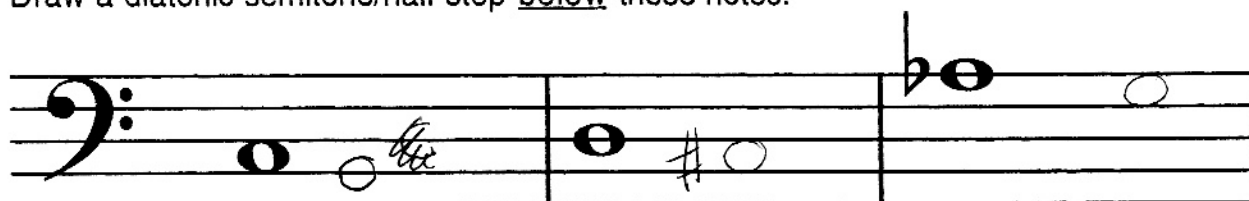

Always use your lollipop keyboard. Draw it here.

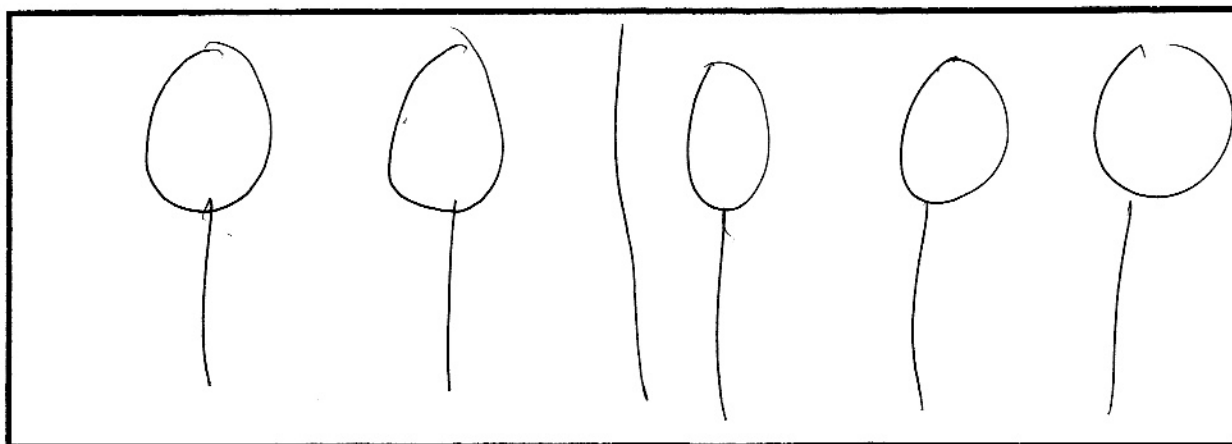

Walk Up The Stairs With Me!

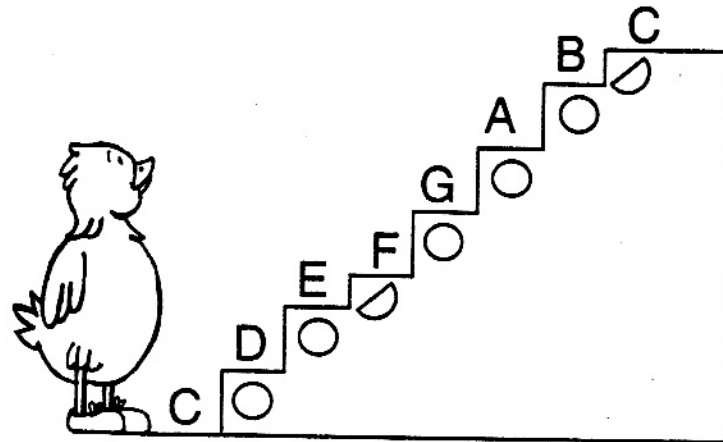

It is a small step between E and F and between B and C.

Where are the half steps/semitones? Circle them.

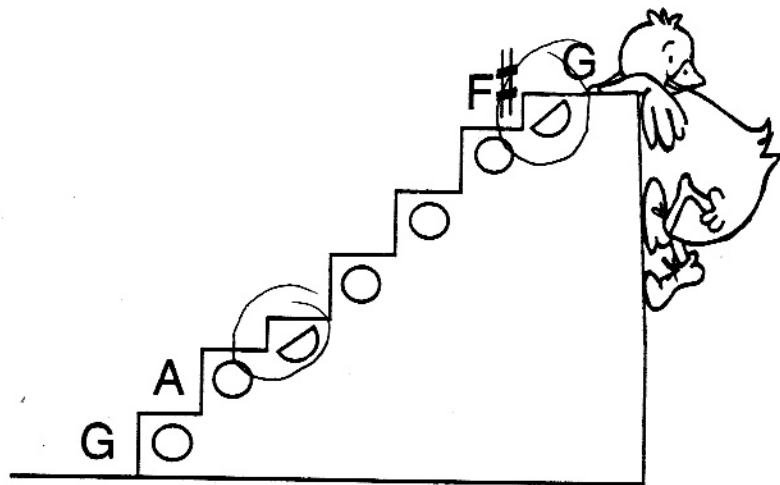

Steps!

The small steps are between E & F

and between B & C in the C scale.

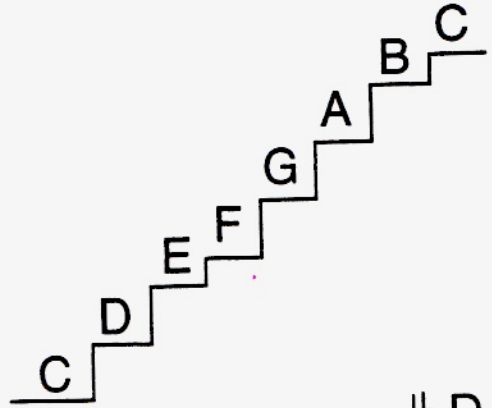

The small steps are between F# & G

and between C# & D in the D scale.

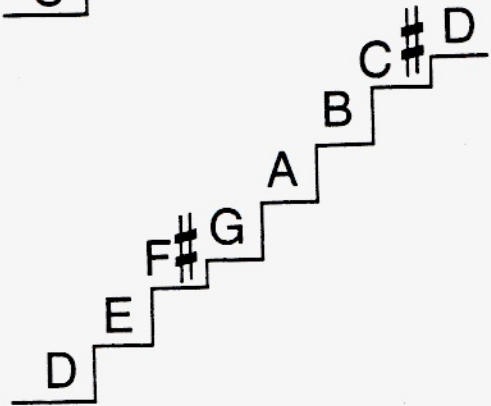

The small steps are always between numbers 3 & 4

and between 7 & 8 in a major scale.

This is the Pattern of the major scale.

Write the D Major Scale ascending here and color F# and G blue and C# and D blue. Remember to draw a clef. → treble or bass.

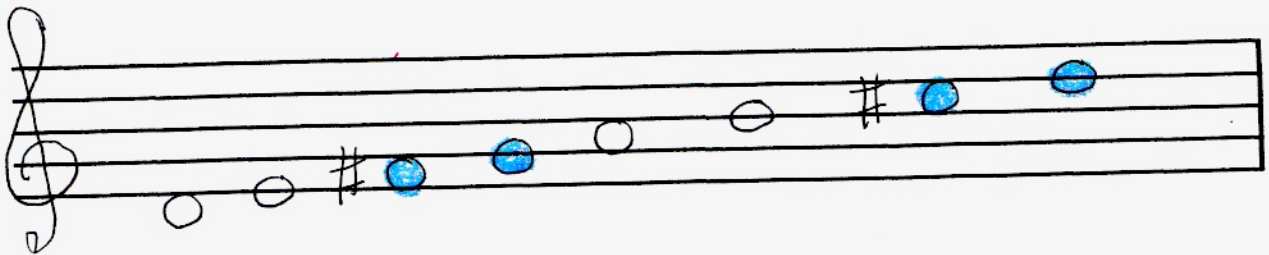



Time Signatures

Add the time signatures.

Write the counts below the notes.

Name the keys. Play one line per day.



Key: F

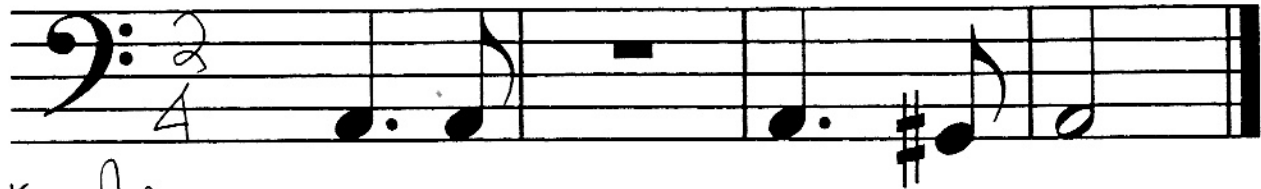

Key: Am



Key: F



Key: D